



WESEM



additional lamps

138 x 78

2HM, 2HMZ

*halogen fog lights
and driving lights*

modern design

watertightness IP65

universal application

Construction and parameters

Application

To be mounted on front parts of cars or trucks.
Designed especially for cars with small bumper cavities.

General information

All metal parts are galvanized with a generous zinc coating to ensure corrosion resistance.
The metallic coating is treated with silicone varnish and silicon for protection.

Detailed information

Construction:

- metal reflector
- black plastic housing
- glass lens
- mounting bracket
- wiring with seal, tipped with F2,5 and A2,5 terminals
- bulb (optional)

Lens colour

Halogen lights are manufactured with clear or amber lens.

Additional features

Compact and attractive design.
Mounting and adjustment system permits easy and accurate 3D aiming.

Bulbs

Fit bulb type:
H3 12V 55W or H3 24V 70W

Additional equipment

Some versions come with a full lens cover (cat. number A.37901) or with a stone guard (cat. number A.37900), which emphasize styling, extend working life and protect from accidental damage.

Parameters

Watertightness IP65.
The driving light guide number which specifies the light's maximum candle power is 12,5 (it is about 60 lx within distance of 25 m).

Mounting methods

Can be mounted on a vehicle as vertically standing or pendent mounting.

Cat. number	Homolog. code	Light function		Lens colour			Accessories	Application	Mounting	bumper cavity	spoiler / front grill	Side			Packaging / pc							
		fog light	driving light	clear	blue	amber						bulb H3 12V	bulb H3 24V	stone guard	lamp cover	wire	connector	universal	dedicated	bracket	right	left
2HM.19071	198	•		•																1		
2HM.19472	198	•		•																	1	
2HMZ.19873	198	•		•																	2	
2HMZ.20274	198	•		•																	2	
2HM.19171	198	•					•														1	
2HM.19572	198	•					•														1	
2HMZ.19973	198	•					•														2	
2HMZ.20374	198	•					•														2	
2HM.19271	200	•		•																	1	
2HM.19672	200	•		•																	1	
2HMZ.20073	200	•		•																	2	
2HMZ.20474	200	•		•																	2	
2HM.19371	200						•														1	
2HM.19772	200						•														1	
2HMZ.20173	200						•														2	
2HMZ.20574	200						•														2	

Homologation code means identifier of certification number.

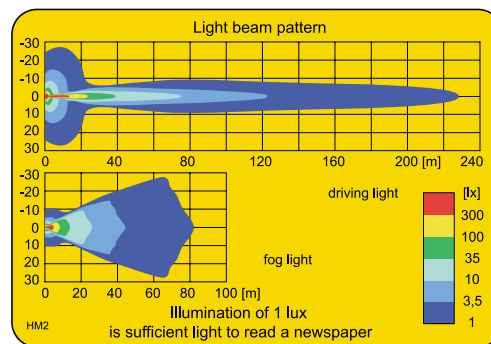
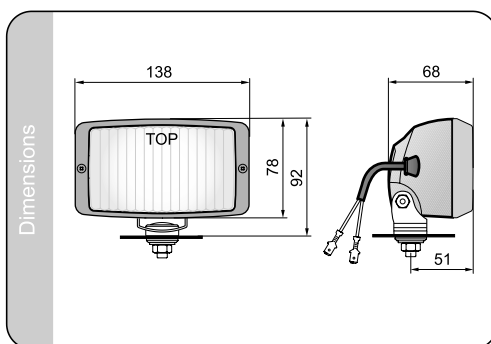
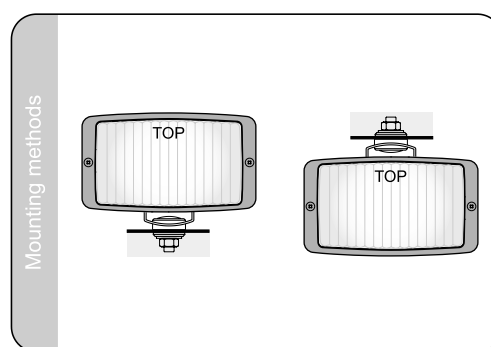
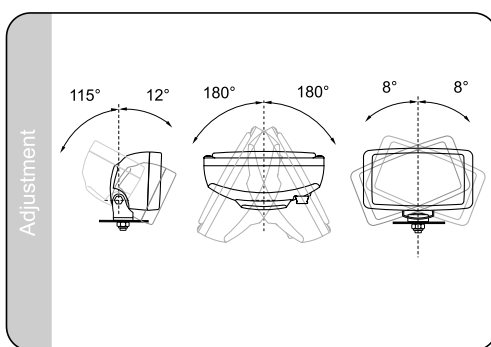

- headlamps
- additional lamps
- work lamps
- special lamps
- signalling lamps
- bicycle lamps
- accessories